

# OWNERS MANUAL

**Model No.  
45-0266**

**CAUTION:**  
Read Rules for  
Safe Operation  
and Instructions  
Carefully

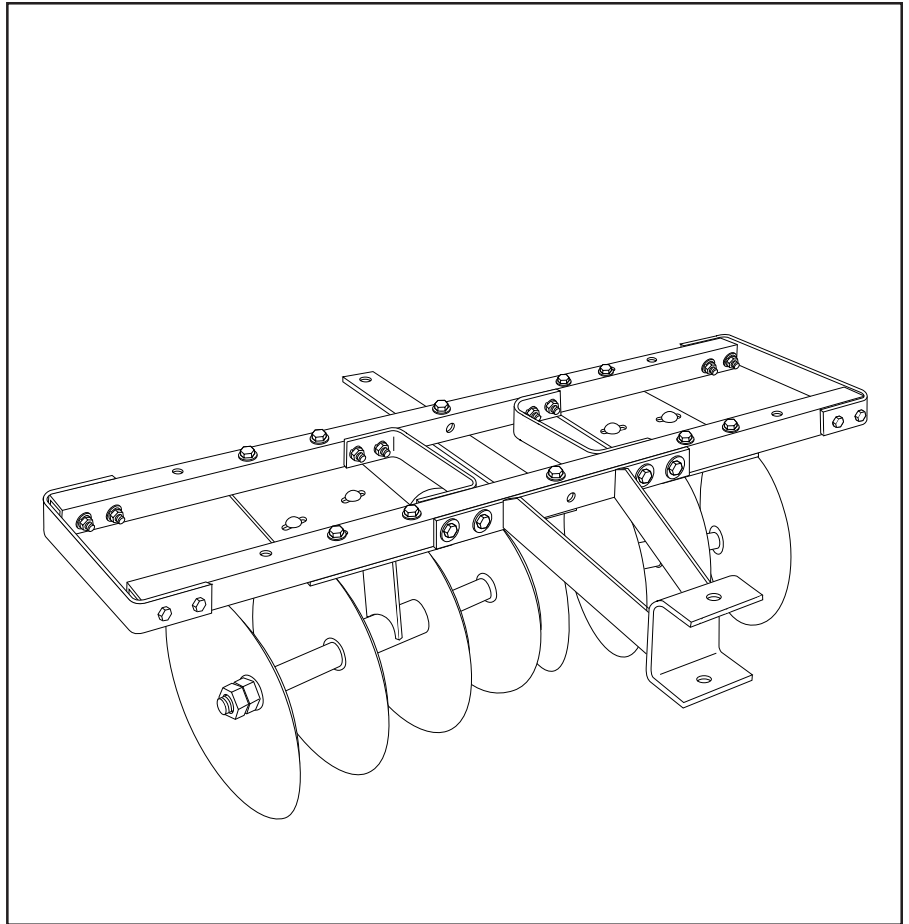

## **DISK CULTIVATOR (SLEEVE HITCH)**

- Assembly
- Operation
- Maintenance
- Parts

## TABLE OF CONTENTS

SAFETY RULES .....	2	OPERATION .....	6
CARTON CONTENTS .....	2	MAINTENANCE .....	6
HARDWARE CHART (FULL SIZE) .....	3	REPAIR PARTS .....	7
ASSEMBLY INSTRUCTIONS .....	4		



## SAFETY



Any power equipment can cause injury if operated improperly or if the user does not understand how to operate the equipment. Exercise caution at all times, when using power equipment.

1. Read this owners manual and your vehicle and sleeve hitch owners manuals before using this equipment.
2. Do not allow children to operate vehicle or disk cultivator.
3. Do not allow adults to operate vehicle or disk cultivator without proper instructions.
4. Do not allow anyone to ride on the disk cultivator.
5. Before lowering and operating the disk cultivator, be sure no one is near the area of operation.
6. Lower disk cultivator when leaving vehicle unattended.
7. Wear substantial footwear when using disk cultivator. The disk edges are sharp!
8. Vehicle braking and stability may be affected with the attachment of this equipment. Drive slowly when disk cultivator is in transport position. **Stay off of steep slopes.**
9. Stop and inspect for damage after striking an object. Repair any damage before continuing operation.
10. Keep all nuts and bolts tight and be sure that the equipment is in safe operating condition.
11. Lock tractor lift handle in down position when attaching or removing disk cultivator from sleeve hitch.



Look for this symbol to point out important safety precautions. It means--**Attention!! Become alert!!** Your safety is involved.

### CARTON CONTENTS

1. Frame Tube
  2. Middle Frame Brace (2)
  3. End Frame Brace (2)
  4. Hitch Assembly
  5. Disk Mounting Plate (2)
  6. Hitch Bar
  7. Disk Blade (8)
  8. Hex Bolt, 3/4" x 16" (2)
  9. Bearing Hanger Bracket (2)
- Hardware Package (see next page)

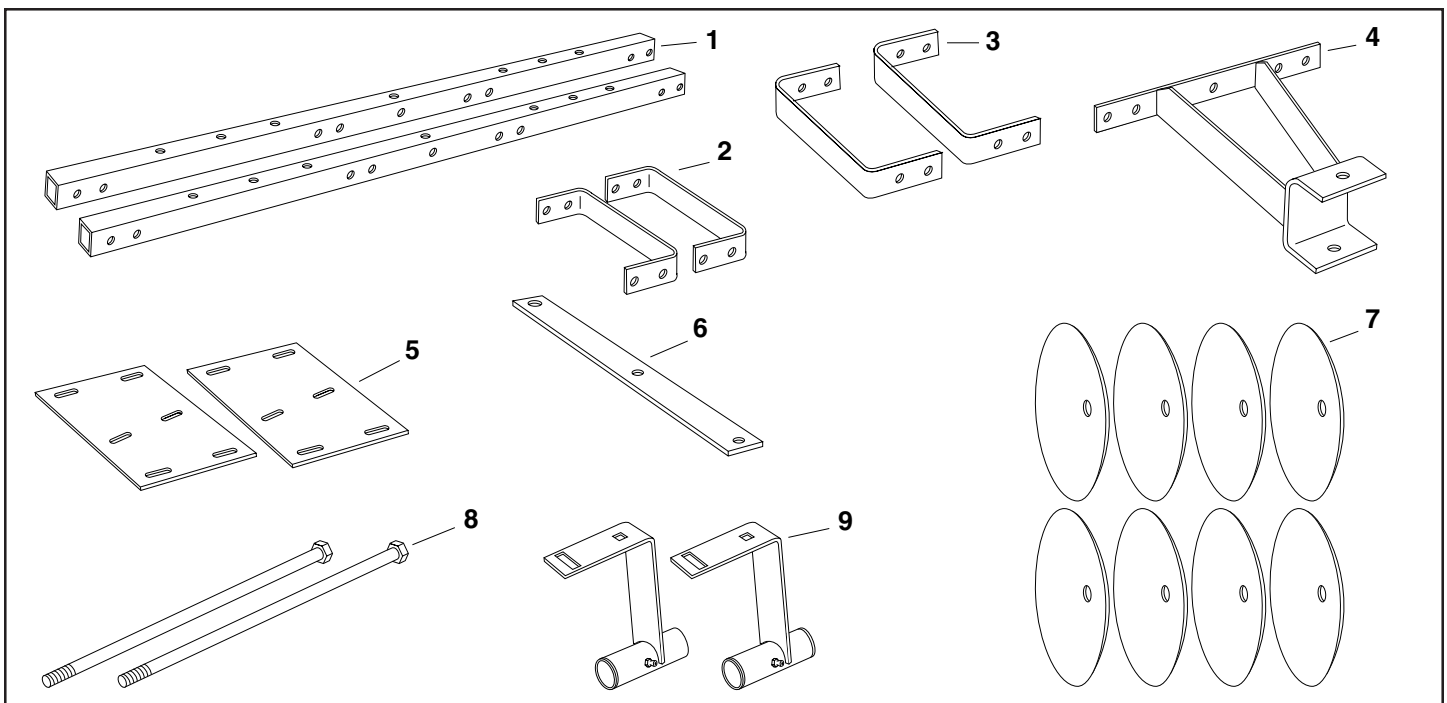

**HARDWARE PACKAGE CONTENTS**

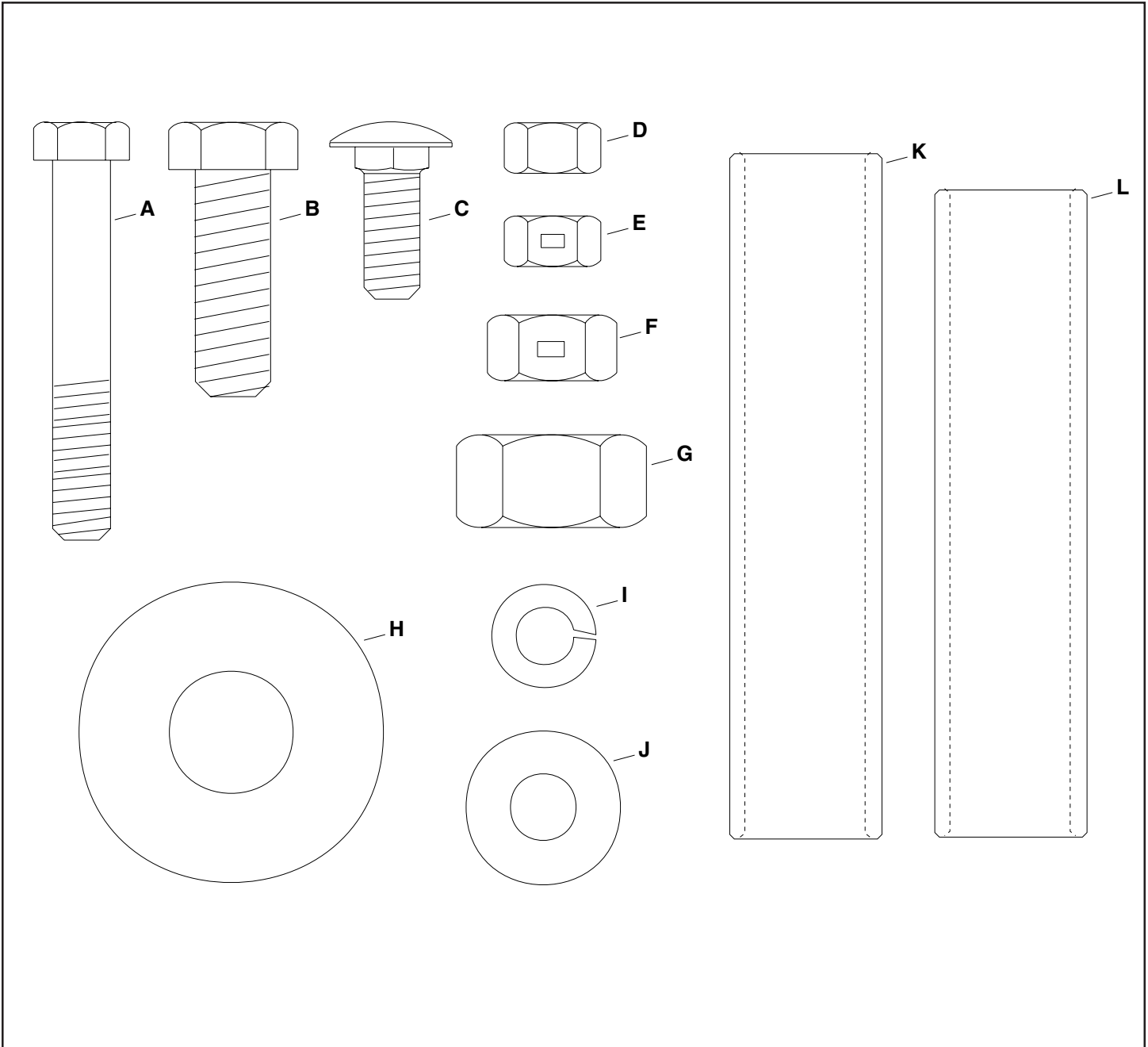

HARDWARE PACKAGE CONTENTS - SHOWN ACTUAL SIZE

REF.	QTY.	DESCRIPTION	REF.	QTY.	DESCRIPTION
A	26	Hex Bolt, 3/8" x 2-1/2" Lg.	G	4	Hex Nut, 3/4"
B	1	Hex Bolt, 1/2" x 1-1/2" Lg.	H	16	Flat Washer, 3/4"
C	4	Carriage Bolt, 3/8" x 1" Lg.	I	30	Lock Washer, 3/8"
D	22	Hex Nut, 3/8"	J	26	Flat Washer, 3/8"
E	8	Hex Lock Nut, 3/8"	K	2	Bearing Sleeve
F	1	Hex Lock Nut, 1/2"	L	4	Spacer

## ASSEMBLY

### TOOLS REQUIRED FOR ASSEMBLY

- (2) 9/16" Wrenches
- (2) 3/4" Wrenches
- (2) 1-1/8" Wrenches or 10" Adjustable Wrenches
- (1) Grease Gun



**CAUTION:** Disk blades have sharp edges. Use care in handling and assembly. Wear gloves for extra protection against cuts.

Remove loose parts and hardware package from the carton. Lay out and identify as shown on pages 2 and 3.

1. Assemble four disks to each bearing hanger bracket using a bearing sleeve (unplated), a 3/4" x 16" hex bolt, eight 3/4" flat washers, two spacers and two 3/4" hex nuts. Be sure the disks face the same direction relative to the hanger bracket as shown in the figure 1. **Tighten** the first hex nut and then **tighten** the second hex nut against the first.
2. Lubricate the bearings through the grease fittings in the bearing hanger bracket assemblies until grease is forced out through the bearings.

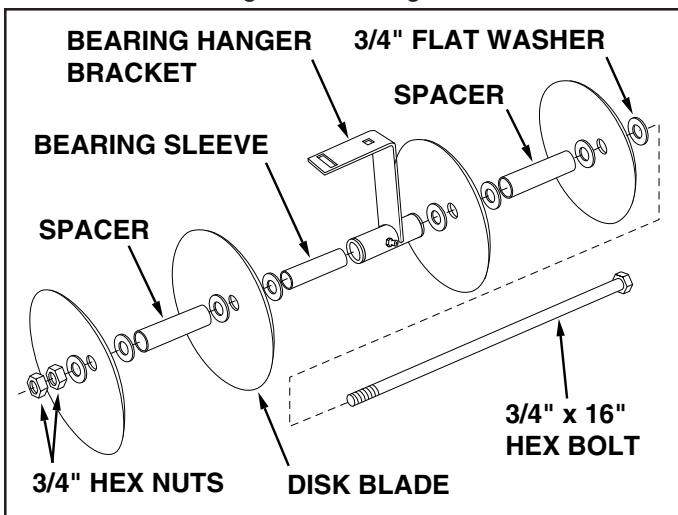

FIGURE 1

3. Assemble the middle frame braces, a frame tube and the hitch assembly together using four 3/8" x 2-1/2" hex bolts, 3/8" lock washers, 3/8" flat washers and 3/8" hex nuts. **Do not tighten yet.** See figure 2.

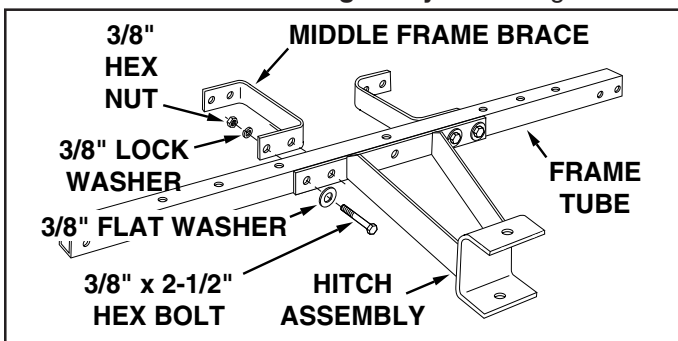

FIGURE 2

4. Assemble a frame tube to the rear of the middle frame braces using four 3/8" x 2-1/2" hex bolts, 3/8" flat washers, 3/8" lock washers and 3/8" hex nuts. **Do not tighten yet.** See figure 3.

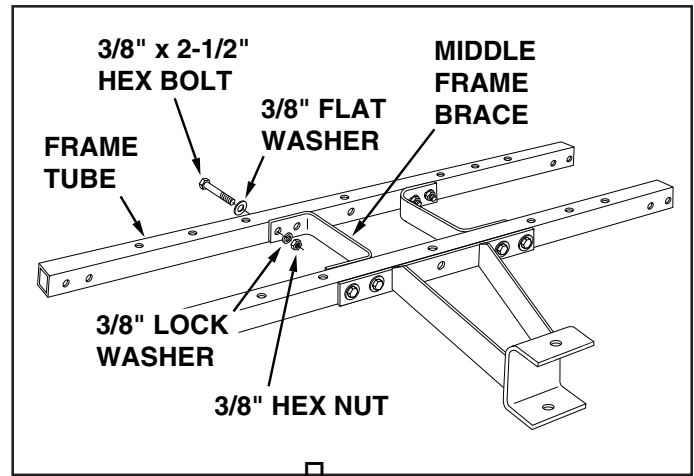

FIGURE 3

5. Assemble a frame end brace over each end of the frame tubes using eight 3/8" x 2-1/2" hex bolts, 3/8" flat washers, 3/8" lock washers and 3/8" hex nuts. See figure 4. **Tighten all bolts** at this time.

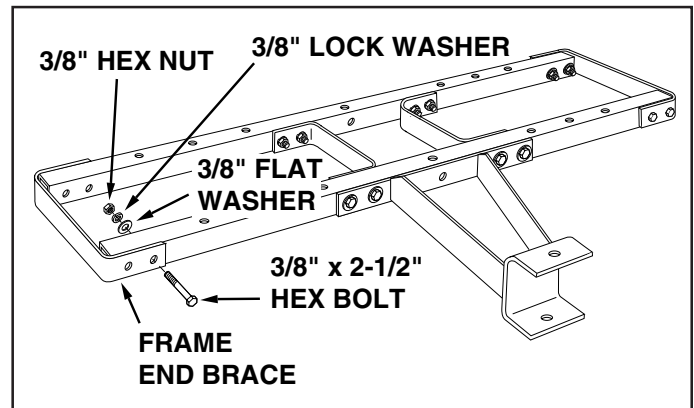

FIGURE 4

6. **For tandem cultivators only.** Assemble the hitch bar to the cultivator frame using two 3/8" x 2-1/2" hex bolts, 3/8" flat washers, 3/8" lock washers and 3/8" hex nuts. **Tighten.** See figure 5.

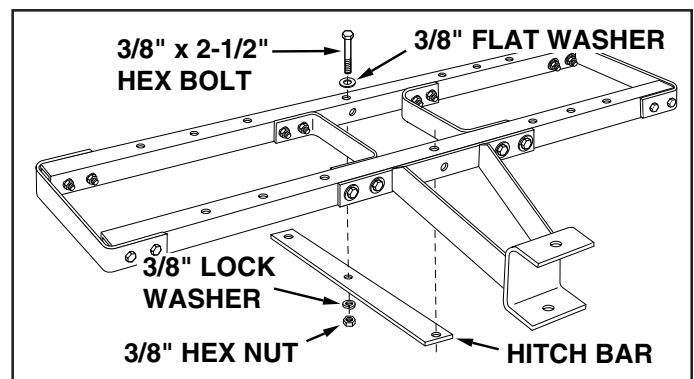

FIGURE 5

### ASSEMBLY OF SINGLE OR FRONT CULTIVATOR

The following instructions describe the disk arrangement commonly used. The disks can also be mounted farther apart by using the outer holes in the frame or they can be angled toward the front center by reversing the disk mounting plates as seen in the tandem instructions. **The dished (concave) side of the disks should always face forward.**

7. Assemble the two disk mounting plates to the frame using eight 3/8" x 2-1/2" hex bolts, 3/8" flat washers (placed under bolt heads), 3/8" lock washers and 3/8" hex lock nuts. The middle slots in the plates should angle toward the rear center of the frame. **Do not tighten yet.** See figure 6.

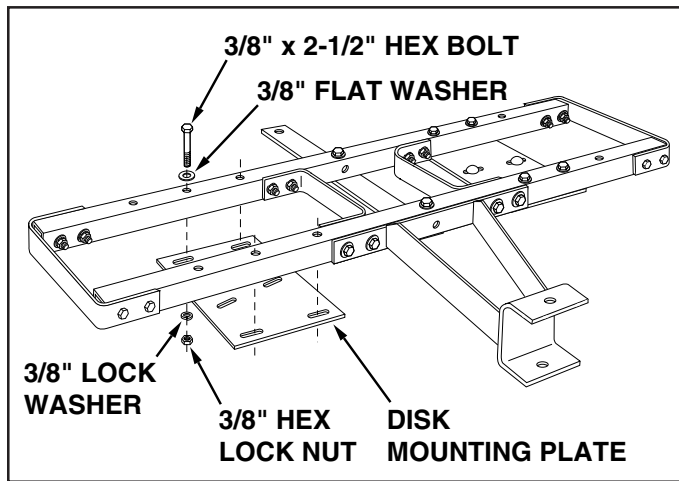

FIGURE 6

8. Assemble the disk assemblies to the disk mount plates using four 3/8" x 1" carriage bolts, 3/8" lock washers and 3/8" hex nuts. With the inside disks almost touching, swivel the disk assemblies until the angle adjustment slot is centered on the carriage bolt. This positions the disks at a 15 degree angle. **Tighten all bolts.** See figure 7.

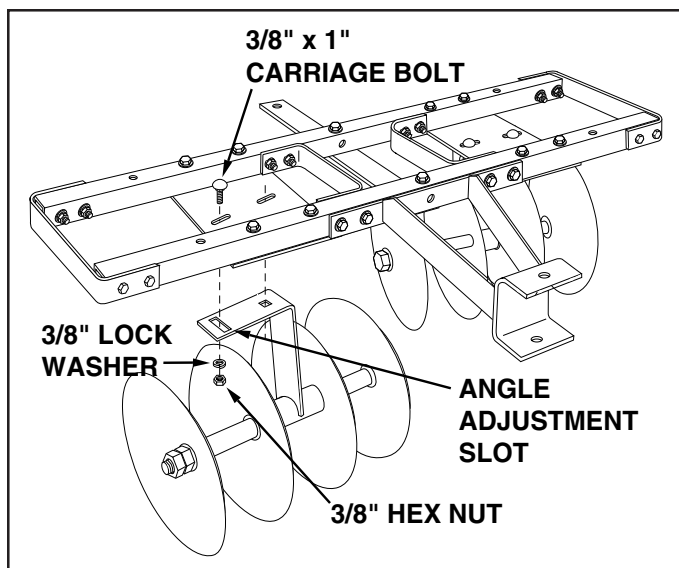

FIGURE 7

### ASSEMBLY OF REAR TANDEM CULTIVATOR

The following instructions are for the assembly of the rear cultivator in a tandem arrangement. (Requires purchase of a second cultivator.) The rear cultivator is towed by the hitch bar instead of the hitch assembly. **The dished (concave) side of the disks should always face forward.**

9. Assemble the two disk mounting plates to the frame using eight 3/8" x 2-1/2" hex bolts, 3/8" flat washers (placed under bolt heads), 3/8" lock washers and 3/8" hex lock nuts. The middle slots in the plates should angle toward the rear corners of the frame. **Do not tighten yet.** See figure 8.

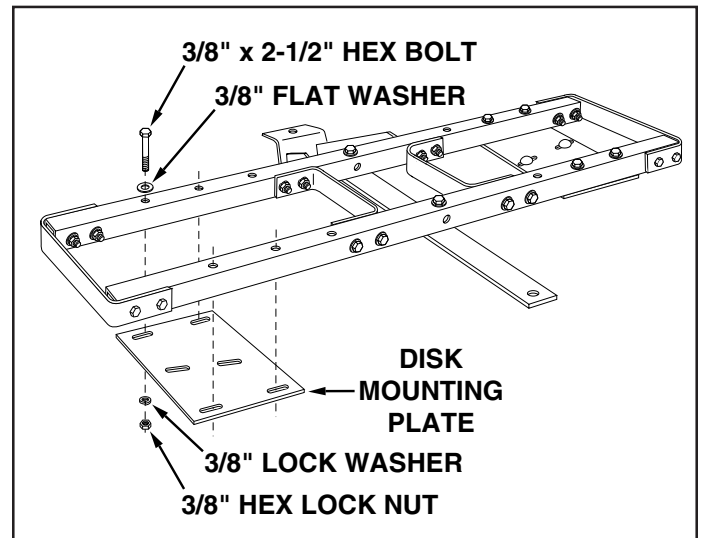

FIGURE 8

10. Assemble the disk assemblies to the disk mount plates using four 3/8" x 1" carriage bolts, 3/8" lock washers and 3/8" hex nuts. With the inside disks spaced 8" to 10" apart, swivel the disk assemblies until the angle adjustment slot is centered on the carriage bolt. This positions the disks at a 15 degree angle. **Tighten all bolts.** See figure 9.

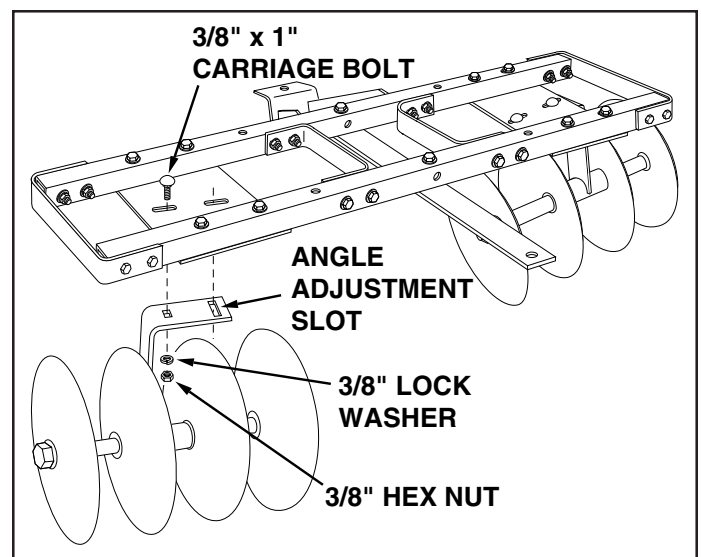

FIGURE 9

## ATTACHING CULTIVATOR TO TRACTOR



**CAUTION:** Lock tractor lift handle in down position when attaching or removing the disk cultivator from sleeve hitch.

Refer to your sleeve hitch owners manual.

1. Remove the stabilizer bolts from the tractor's sleeve hitch as shown in figure 9 to allow side to side motion of the disk cultivator.
2. Attach the disk cultivator to the sleeve hitch on your tractor using the sleeve hitch pin.
4. Adjust the sleeve hitch so that the disk cultivator is free to lower below ground level but can still be raised an adequate distance above ground for transport.

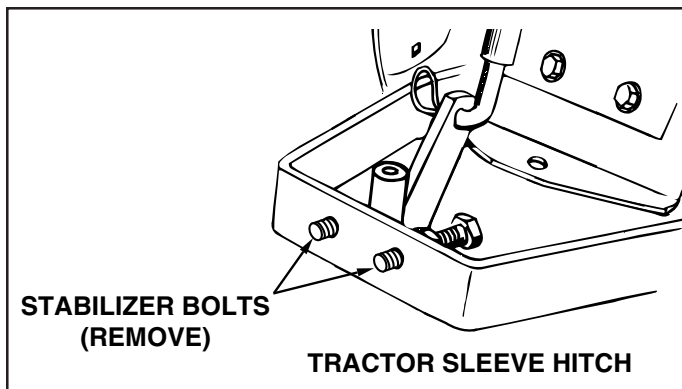

FIGURE 10

## ATTACHING TANDEM CULTIVATORS

1. Attach the front cultivator as instructed above.
2. Attach the rear cultivator to the front cultivator by fastening the hitch bars together using a 1/2" x 1-1/2" hex bolt and a 1/2" hex lock nut. Do not completely tighten the bolt, allowing a slight amount of play between the hitch bars. See figure 11.



**CAUTION:** Do not attempt to raise the tractor sleeve hitch when connected to disk cultivators in tandem arrangement.

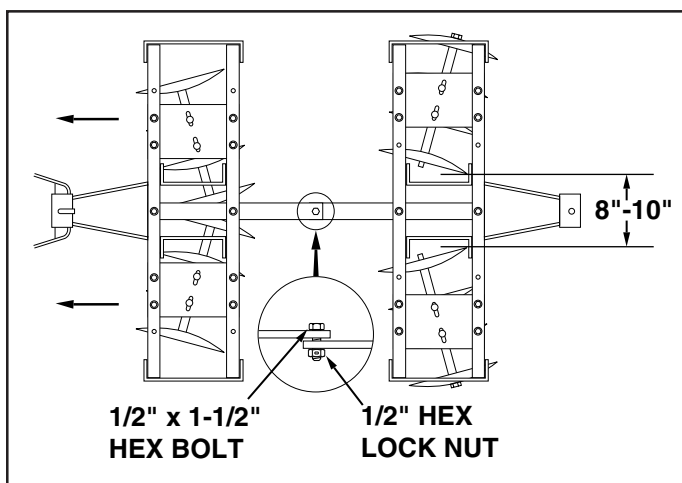

FIGURE 11

## OPERATION

The disk cultivator is used to break up clods of dirt in plowed soil. It can also be used to cultivate between rows of young plants.

1. Before starting make sure the soil is dry enough by squeezing some in your hand. If it forms a ball that doesn't crumble then the soil is too wet for disking. Wet soil will pack between the disk blades.
2. Adjust the disks to the desired angle setting. The angle can be varied from 10 to 20 degrees. Start with a setting of 15 degrees (the carriage bolt centered in the angle adjustment slot in the bearing hanger bracket). The greater the angle, the greater the disking action.
3. To break up dirt clods in plowed soil, start disking slowly at first. As the clods are broken up the speed may be gradually increased. Disk the soil using a crisscross pattern for best results.
4. To use two cultivators in tandem, the disk assemblies should be positioned as shown in figure 11, with the inside disks almost touching on the front cultivator and 8" to 10" apart on the rear cultivator. With this arrangement the front cultivator will throw the dirt to the outside and the rear cultivator will throw the dirt back to the inside.
5. To cultivate young crops by straddling the rows, move the disks to the maximum width setting. To throw the dirt to the outside, away from the row, mount the disks to angle rearward in the center. To throw dirt to the inside, to smother young weeds in the crop row, mount the disks to angle forward in the center.
6. Up to 100 lbs. of weight may be added to help increase penetration. Concrete blocks or other weight may be tied or strapped to the cultivator frame. The cultivator should be attached to the tractor's sleeve hitch in the down position before adding weight.

## MAINTENANCE

1. Check for loose bolts after each use.
2. Clean the disks and lightly oil any exposed metal after each use.
3. Remove all dirt and rust and touch up with paint before storing.
4. Store inside a dry area.

**PARTS**

**REPAIR PARTS FOR MODEL 45-0266 - DISK CULTIVATOR**

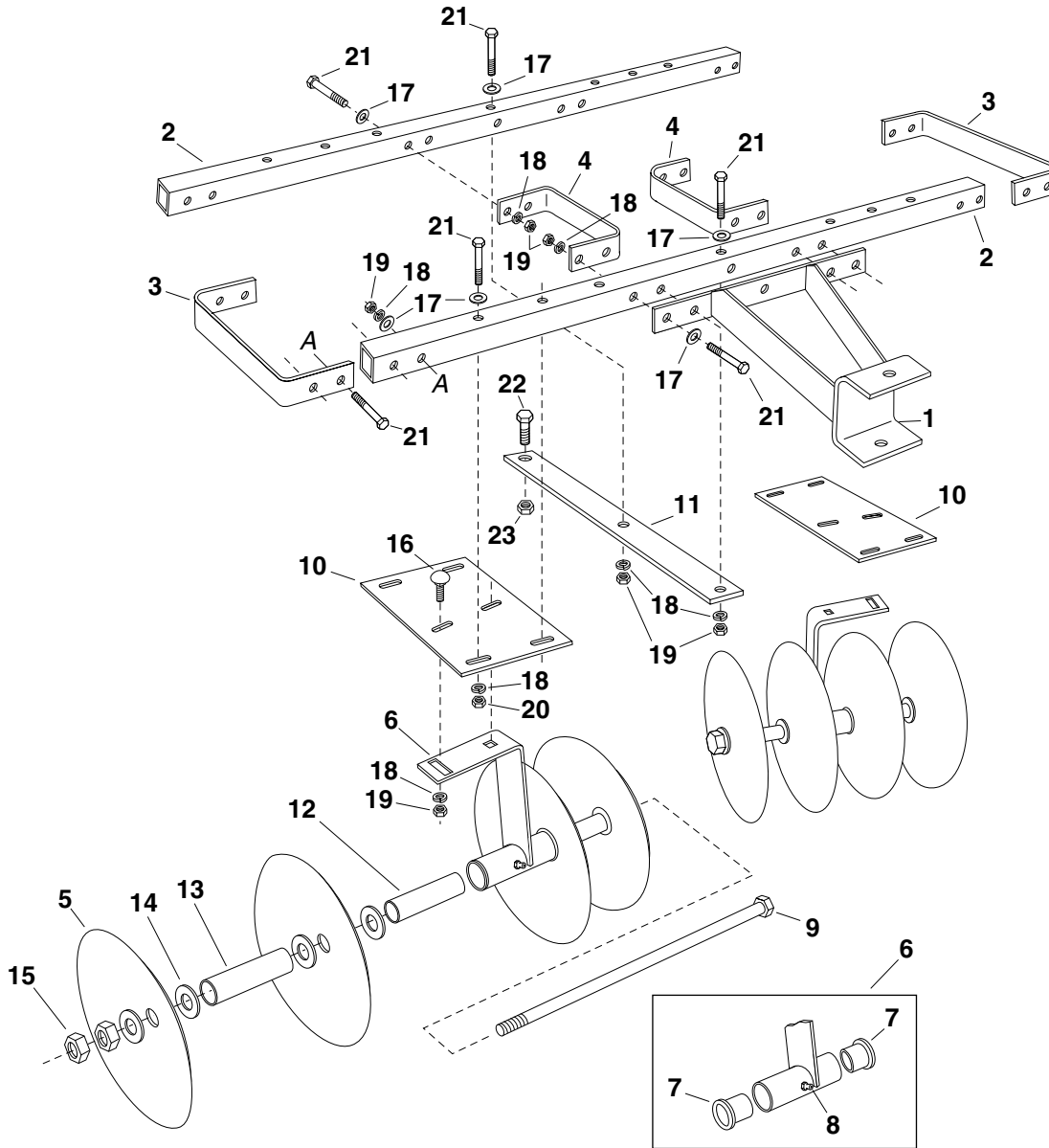

REF. NO.	PART NO.	QTY.	DESCRIPTION	REF. NO.	PART NO.	QTY.	DESCRIPTION
1	63656	1	Hitch Assembly.	13	46859	4	Spacer, 3/4" I.D. x 4-1/4" Lg.
2	46848	2	Frame Tube	14	1540-162RM	16	Flat Washer, 3/4" Std. Wrt.
3	24223	2	Frame Brace (End)	15	46860	4	Hex Nut, 3/4-10 Thread
4	24224	2	Frame Brace (Middle)	16	43350	4	Carriage Bolt, 3/8-16 x 1" Lg.
5	46856	8	Blade Disk	17	43070	26	Washer, 3/8" Std. Wrt.
6	63510	2	Bearing Hanger Brkt. Assembly.	18	43003	30	Lock Washer, 3/8"
7	44488	4	Bearing (Included in #63510)	19	43015	22	Hex Nut, 3/8-16 Thread
8	46858	2	Grease Fitting (Included in #63510)	20	43082	8	Hex Lock Nut, 3/8-16 Thread
9	46857	2	Hex Bolt, 3/4-10 x 16" Lg.	21	43432	26	Hex Bolt, 3/8-16 x 2-1/2" Lg.
10	24226	2	Disk Mounting Plate	22	43020	1	Hex Bolt, 1/2-13 x 1-1/2" Lg.
11	24241	1	Hitch Bar	23	43262	1	Hex Lock Nut, 1/2-13 Thread
12	24240	2	Bearing Sleeve		47057	1	Owners Manual

For Agri Fab Discount Parts Call 606-678-9623 or 606-561-4983

**REPAIR PARTS**

303 West Raymond  
Sullivan, IL. 61951  
217-728-8388